

# TechBriefs

## Savannah River National Laboratory

U.S. DEPARTMENT OF ENERGY • SAVANNAH RIVER SITE • AIKEN • SC

[srnl.doe.gov](http://srnl.doe.gov)

### Benefits

- > Analysis of high speed events
- > Ability to monitor a system over time using spectroscopy

### Applications

- > Monitor chemical transformations
- > Monitor high energy chemical detonations
- > Laser induced sample excitation

### Contact Information

Savannah River National Laboratory  
E-mail: [partnerships@srnl.doe.gov](mailto:partnerships@srnl.doe.gov)



## High Speed Spectroscopy Using Temporal Positioned Optical Fibers with an Optical Scanner Mirror

### Technology Overview

Savannah River National Laboratory (SRNL) has developed a state-of-the-art optical measurement system and methodologies that can be used to examine a high speed event with a resolution on the order of a millisecond or less.

### Description

Spectrophotometers can measure the optical spectrum from the light-matter interaction. The spectral analysis is usually limited to a single snapshot of an event at a particular time corresponding to the detector integration time and the speed of the signal. SRNL has developed a state of the art optical measurement system and methodologies that can be used to examine a transient phenomenon and capture the spectra from a series of time frames with an accuracy of a millisecond to microsecond temporal range. In this setup, light from the event is reflected off a polygon mirror and redirected to one or more additional collecting lenses of one or more additional optical waveguides at the slit of spectrometer. Each waveguide illuminates a pixel row in the detector producing an optical spectrum corresponding to a time segment in the evolution of the transient event.

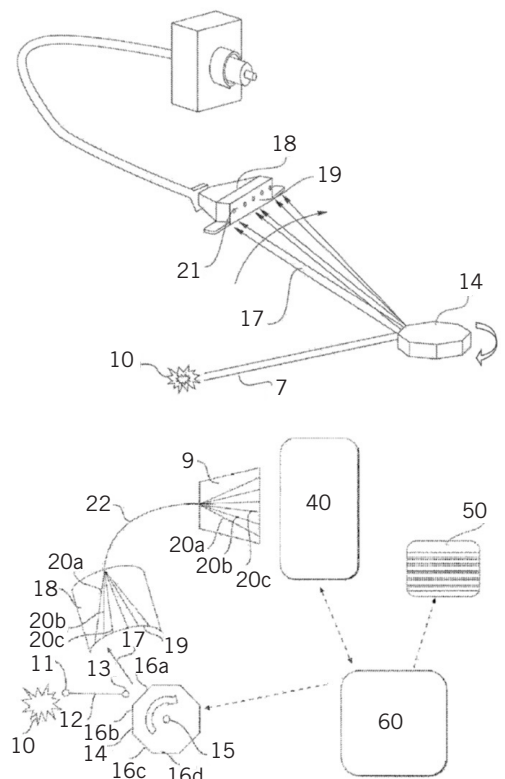

Savannah River National Laboratory®

# TechBriefs

## Savannah River National Laboratory

### Technology transfer

The Savannah River National Laboratory (SRNL) is the U.S. Department of Energy's (DOE) applied research and development laboratory at the Savannah River Site (SRS).

With its wide spectrum of expertise in areas such as homeland security, hydrogen technology, materials, sensors, and environmental science, SRNL's cutting edge technology delivers high dividends to its customers.

The management and operating contractor for SRNL is Battelle Savannah River Alliance, LLC. BSRA is responsible for transferring its technologies to the private sector so that these technologies may have the collateral benefit of enhancing U.S. economic competitiveness.

### Intellectual Property

This technology and methods for its use have been granted U.S. Patent No. 10,126,231 B2 (November 11, 2018), "High Speed Spectroscopy Using Temporal Positioned Optical Fibers with an Optical Mirror" and is available for licensing.

### Partnering opportunities

SRNL invites interested companies with proven capabilities in this area of expertise to develop commercial applications for this process under a cooperative research and development agreement (CRADA) or licensing agreement. Interested companies will be requested to submit a business plan setting forth company qualifications, strategies, activities, and milestones for commercializing this invention. Qualifications should include past experience at bringing similar products to market, reasonable schedule for product launch, sufficient manufacturing capacity, established distribution networks, and evidence of sufficient financial resources for product development and launch.

SRNL-L1100-2020-00110



Savannah River National Laboratory®